



Apacer

Apacer Industrial Solutions (SSD & DRAM)

**Access Endless Possibilities for
a Sustainable Tomorrow**



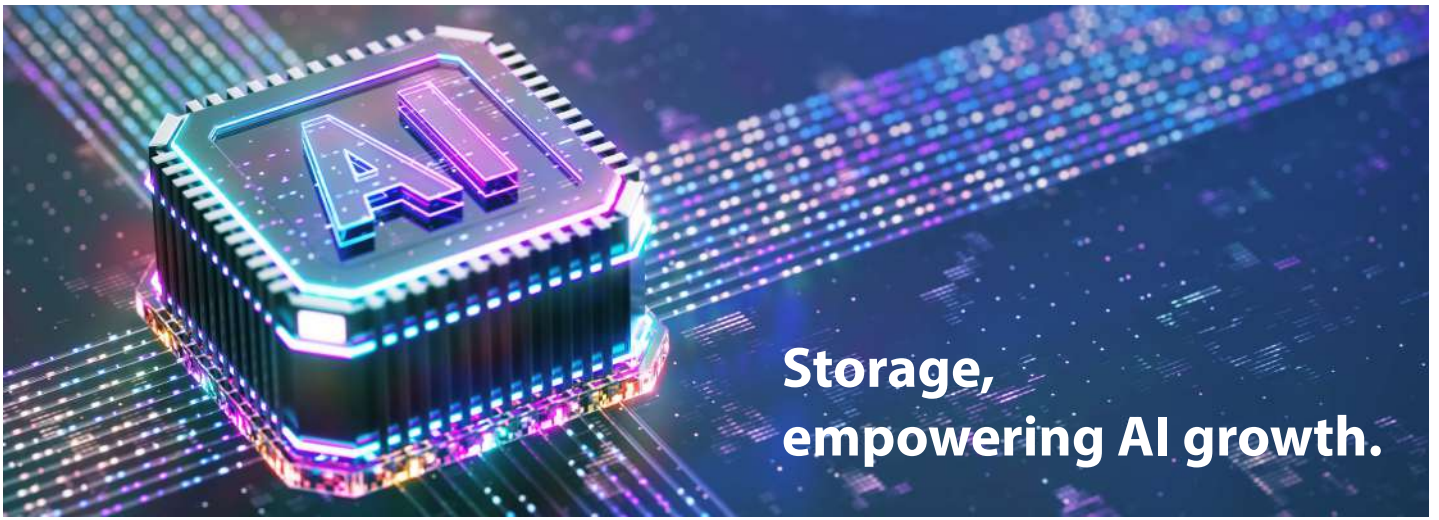

Storage, empowering AI growth.

For over two decades, Apacer has redefined the role of storage across diverse global industries and markets. Today, we are entering a pivotal new chapter—evolving our foundation in high-performance storage to drive Edge AI. By combining data-driven technologies with ultra-reliable engineering, we deliver smart-integrated storage solutions that empower critical applications in robotics, smart manufacturing, modern mobility, and next-generation IoT.

In collaboration with our leading ecosystem partners, we enable enterprises to process data closer to the source—achieving higher efficiency, enhanced reliability, and sustainable innovation for a better tomorrow.

Highlighted SSD Technologies



CoreVolt 2 REAL-TIME SSD POWER STABILIZATION FOR DATA PROTECTION



In today's computing environments, system reliability is essential for maintaining data integrity and ensuring smooth operations. CoreVolt 2 technology provides real-time voltage detection and protection against voltage instability. When voltage fluctuations are detected, the SSD automatically **engages backup power supplied by tantalum polymer capacitors to stabilize the voltage**, ensuring uninterrupted operation.

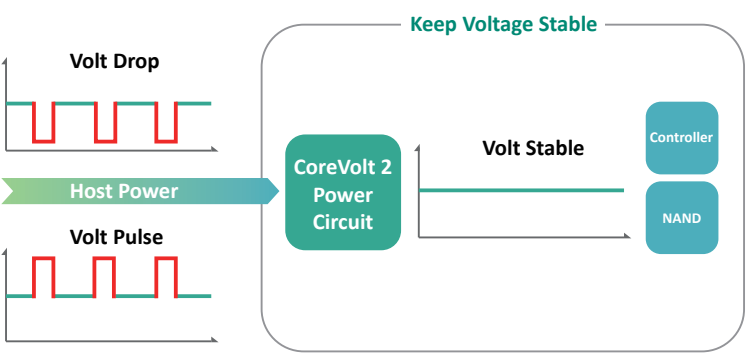

Figure 1: CoreVolt 2 – Power Stabilization Mechanism



Figure 2: CoreVolt 2 – Real-time Monitoring Software



CoreEnergy

APPLICATION-AWARE SSD POWER MANAGEMENT ENHANCES ENERGY EFFICIENCY



As demand grows for storage that balances performance with lower power consumption, energy-efficient solutions are becoming essential across industries.

CoreEnergy delivers **effective energy savings through intelligent and advanced settings**, enabling users to configure energy modes tailored to specific application needs, significantly reducing power usage. It offers multiple selectable energy settings. When default intelligent settings do not suffice, users can fine-tune configurations via the advanced energy settings.

Intelligent Energy Settings

Adjusting by ① software interface — default 5 settings or ② hardware DIP switch.



Advanced Energy Settings

Fine-tune by adjusting ③ software interface — 3 dimensions (PCIe Gen, PCIe Lane, and Access Mode).



Anti-Sulfuration

INDUSTRIAL-GRADE PROTECTION AGAINST CORROSION FOR SUSTAINED RELIABILITY



In harsh industrial environments, sulfur-containing gases and pollutants can chemically attack electronic components, leading to corrosion, increased resistance, and system failures.

Apacer's patented Anti-Sulfuration technology uses specially engineered **alloy materials in key components to resist Sulfur-induced corrosion**. This advanced protection ensures stable, long-term operation even in sulfur-rich and highly polluted conditions. Anti-Sulfuration products also meet stringent industrial air corrosion standards, significantly extending system lifespan and improving reliability in demanding environments.

Anti-Sulfuration technology comparison table

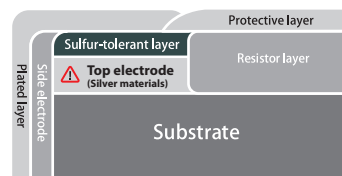
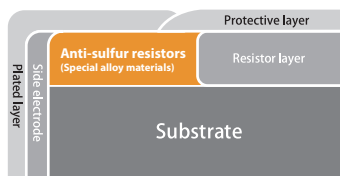

Apacer's advanced Anti-Sulfuration technology

Traditional Anti-Sulfuration technology

Method	Apacer's advanced Anti-Sulfuration technology	Traditional Anti-Sulfuration technology
Method	Adopts exclusive and improved alloy materials replace normal electrode	Covers an Sulfur-tolerant layer to protect the electrode
Advantages / Disadvantages	Reliable Anti-sulfuration performance, improved product reliability and durability	Unstable Anti-sulfuration performance due to process failure

SSD Line-Up

FIPS TCG SSD Series



Form Factor	2.5", M.2 2280, MO-300, MO-297
Interface	SATA 3.2 (6Gb/s)
NAND Flash Type	3D TLC
Capacity	240GB-1920GB
Key Features	<ul style="list-style-type: none"> • FIPS 140-2 Level 2 certified: certificate number #4386 • TCG Opal 2.0/AES 256-bit Encryption • Wide Temperature • SMART Read Refresh™ • S.M.A.R.T. function

 Certificate #4386

Compatible With Raspberry Pi Platforms Series



Form Factor	M.2 2242, microSD, HAT
Interface	PCIe Gen4 x4, SD 6.1
NAND Flash Type	3D TLC
Capacity	64GB-1TB
Key Features	<ul style="list-style-type: none"> • Global Wear-leveling • Flash Bad-block Management • Flash Translation Layer: Page Mapping • SSDWidget 2.0 and S.M.A.R.T. function • Power Failure Management • End-to-End Data Protection • TRIM Support • SMART Read Refresh™ • NVMe Secure Erase • Instant Keychange™ (optional) • CorePower (optional) • Write Protect (optional) • CoreRescue (optional) • CoreSnapshot 2 (optional)

Enterprise Series



Form Factor	2.5", M.2 2280, M.2 22110, U.3, U.2, EDSFF E1.S, E3.S
Interface	PCIe Gen5 x4, Gen4 x4, SATA 3.2 (6Gb/s)
NAND Flash Type	3D TLC, 3D eTLC
Capacity	480GB-30.72TB
Key Features	<ul style="list-style-type: none"> • Core Power • QoS 99.9% • DWPD (5 years) >1~3 • Global Wear-leveling • SSDWidget 2.0 and S.M.A.R.T. function • Over-provisioning • SMART Read Refresh™ • NVMe Secure Erase • Namespace (optional) • TCG Opal 2.0/AES 256-bit Encryption (optional)

PCIe SSD



Form Factor	M.2 2280, M.2 2242, M.2 2230, U.2, CFexpress, BGA SSD
Interface	PCIe Gen4 x4, Gen3 x4, Gen3 x2
NAND Flash Type	3D TLC, SLC-liteX
Capacity	40GB-8192GB
Key Features	<ul style="list-style-type: none"> • Single-side (applicable) • Built-in LDPC ECC and S.M.A.R.T. function • Built-in Hyper Cache Technology and Power Failure Management • Over-Provisioning • Thermal Throttling • Wide Temperature (optional) • Anti-Sulfuration (optional) • SLC-liteX Technology (optional) • CorePower (optional) • Write Protect (optional) • CoreSnapshot 2 (optional) • CoreEnergy (optional) • CoreVolt2 (optional) • Instant KeyChange™ (optional) • TCG Opal 2.0 (optional)

SATA SSD

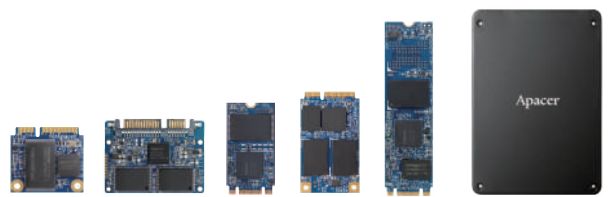

Form Factor	M.2 2280, M.2 2242, 2.5", 1.8", MO-297, MO-300, MO-300B
Interface	SATA 3.2 (6Gb/s)
NAND Flash Type	3D TLC, MLC, SLC, SLC-liteX
Capacity	8GB-16384GB
Key Features	<ul style="list-style-type: none"> • Single-side (applicable) • ATA Secure Erase and S.M.A.R.T. functions • TRIM command • End-to-End Data Protection* • Over-Provisioning* • Hyper Cache Technology* • DataDefender™ • DataRAID™ • DEVSLP (optional) • TCG Opal (optional) • Thermal Throttling (optional) • SLC-liteX Technology (optional) • Instant KeyChange™ (optional) • CorePower (optional) • Anti-Sulfuration (optional) • CoreSnapshot 2 (optional) • Wide Temperature (optional) • Write Protect (optional)

SATA μ SSD



Form Factor	MO-276
Interface	SATA 3.2 (6GB/s)
NAND Flash Type	3D TLC
Capacity	30GB-240GB
Key Features	<ul style="list-style-type: none"> • SoC (System on Chip)/ SiP (System in Chip) technology • Built-in S.M.A.R.T. function • DEVSLP • Wide Temperature • DataRAID™ • Over-Provisioning Technology • Write Protect (optional) • TRIM command (optional) • Hyper Cache Technology (optional)

SATA Module



Form Factor	SSD Module
Interface	SATA 3.2 (6GB/s), PATA
NAND Flash Type	3D TLC, MLC, SLC, SLC-liteX
Capacity	1GB-256GB
Key Features	<ul style="list-style-type: none"> • 7pin/22pin connector • Global Wear Leveling • Flash Block Management • Built-in ATA Secure Erase and S.M.A.R.T. function • Wide Temperature • TRIM command • Over-Provisioning* • DataRAID™ * • Power failure management • Multi-Power Path technology (optional for 7pin SDM) • Write Protect (optional) • SLC-liteX Technology (optional)

CFast Card



Form Factor	CFast Card
Interface	SATA 3.2 (6GB/s)
NAND Flash Type	3D TLC, MLC, SLC, SLC-liteX
Capacity	2GB-960GB
Key Features	<ul style="list-style-type: none"> • Advanced wear-leveling technology • Flash Block Management • Built-in ATA secure erase and S.M.A.R.T. function • Built-in LDPC ECC* • TRIM command available • End-to-End Data Protection* • Over-Provisioning • DEVSLP (optional) • CorePower (optional) • Write Protect Switch (optional) • SLC-liteX Technology (optional)

eMMC



Form Factor	153 Ball FBGA
Interface	eMMC5.1 HS400
NAND Flash Type	TLC, MLC, SLC-liteX
Capacity	16GB-128GB
Key Features	<ul style="list-style-type: none"> • Internal error correction code (ECC) • Internal enhanced data management algorithm • Power-loss data protection • Secure bad block erase commands • Enhanced write protection with permanent and partial options • Field firmware update (FFU) • Low Power Consumption • Wide Temperature (optional) • SLC-liteX Technology (optional)

WORM Card & Drive



Form Factor	SD, microSD, USB Flash Drive
Interface	SD 6.1, USB 2.0
NAND Flash Type	3D TLC
Capacity	8GB-128GB
Key Features	<ul style="list-style-type: none"> • Write Once Read Many • Ensure data integrity with non-rewritable storage function • Data retention: 100 years • S.M.A.R.T. function • SMART Read Refresh™ • Built-in advanced ECC algorithm • Global Wear Leveling • Flash bad-block management • Power Failure Management • Flash Translation Layer: Page Mapping

Industrial CF Card



Form Factor	CF Card
Interface	PC Card Memory Mode, PC Card I/O Mode, True IDE Mode
NAND Flash Type	MLC, SLC, SLC-liteX
Capacity	256MB-128GB
Key Features	<ul style="list-style-type: none"> • Advanced Wear-Leveling technology • Flash Block Management • Built-in ATA Secure Erase and S.M.A.R.T. function • Intelligent power failure management • Lock switch design for write-protection (optional) • Wide Temperature (optional) • SLC-liteX Technology (optional)

Industrial microSD & SD Card



Form Factor	microSD, SD Card
Interface	SD2.0, SD3.0, SD5.1, SD6.1
NAND Flash Type	3D TLC, MLC, SLC, SLC-liteX
Capacity	256MB-512GB
Key Features	<ul style="list-style-type: none"> • Supports SD and SPI modes • Global Wear Leveling and Flash Block Management • Low power consumption • Read disturb management • Smart Read Refresh™ • S.M.A.R.T. function • Power failure management • SLC-liteX Technology (optional) • Wide Temperature (optional) • Flash Translation Layer: Page Mapping(optional)

USB Disk Module



Form Factor	USB Disk Module
Interface	USB2.0, USB3.2 Gen1
NAND Flash Type	3D TLC, MLC, SLC, SLC-liteX
Capacity	8GB-256GB
Key Features	<ul style="list-style-type: none"> • Built-in S.M.A.R.T. function • Shock resistance, anti-vibration • Low power consumption • 3D TLC support page mapping • Linux/Win7/Win10 (optional) • Wide Temperature (optional) • Pitch size 2.00 mm and 2.54 mm supported (optional) • Lock switch design for write-protection (optional)

USB Drive



Form Factor	USB Flash Drive
Interface	USB2.0, USB3.2 Gen1, USB Type-A, Type-C
NAND Flash Type	3D TLC, MLC, SLC, SLC-liteX
Capacity	256MB-1TB
Key Features	<ul style="list-style-type: none"> • Compliant with USB3.2 Gen1 Type-C (UV110-UFD7, UH110-UFD7) • Built-in ECC engine and S.M.A.R.T. function • Power saving implementation • Advanced Wear-Leveling algorithms • 3D TLC support page mapping • Chip-On-Board technology: water, moisture, dust, and shock resistant (UT110-UFD2 64GB only) • Lock switch design for write-protection (UH110-UFD4: 4GB-8GB with SLC-liteX) • ESD Prevention: Air discharge ±15KV (UV110-UFD5) • Wide Temperature (optional)

DRAM Line-Up

Embedded Memory

UDIMM



Model Name	DDR5 CUDIMM	DDR5 UDIMM	DDR4 UDIMM	DDR3 UDIMM	DDR2 UDIMM	DDR UDIMM
Speed	6400	4800/5600	2133/2400/2666/2933/3200	1066/1333/1600/1866	533/667/800	266/333/400
Density	8GB/16GB/32GB/48GB/64GB	8GB/16GB/32GB/48GB	2GB/4GB/8GB/16GB/32GB	1GB/2GB/4GB/8GB/16GB	1GB/2GB/4GB	512MB/1GB
Voltage	1.1v	1.1v	1.2v	1.5v/1.35v	1.8v	2.5v/2.6v
Pin Count	288-Pin	288-Pin	288-Pin	240-Pin	240-Pin	184-Pin
Width	64-Bit	64-Bit	64-Bit	64-Bit	64-Bit	64-Bit
PCB Height	1.23"	1.23"	1.23"	1.18"	1.18"	1.25"
Operating Temperature (°C)	TC=0°C to 85°C/ TC=-40°C to 85°C	TC=0°C to 85°C/ TC=-40°C to 85°C	TC=0°C to 85°C/ TC=-40°C to 85°C	TC=0°C to 85°C/ TC=-40°C to 85°C	TC=0°C to 85°C	TC=0°C to 70°C
Fully Lead-free Resistor	Yes	Yes	-	-	-	-

Embedded Memory

SODIMM



Model Name	DDR5 CSODIMM	DDR5 SODIMM	DDR4 SODIMM	DDR3 SODIMM	DDR2 SODIMM	DDR SODIMM
Speed	6400	4800/5600	2133/2400/2666/2933/3200	1066/1333/1600/1866	533/667/800	266/333/400
Density	8GB/16GB/32GB/48GB/64GB	8GB/16GB/32GB/48GB	2GB/4GB/8GB/16GB/32GB	1GB/2GB/4GB/8GB/16GB	1GB/2GB/4GB	512MB/1GB
Voltage	1.1v	1.1v	1.2v	1.5v/1.35v	1.8v	2.5v/2.6v
Pin Count	262-Pin	262-Pin	260-Pin	204-Pin	200-Pin	200-Pin
Width	64-Bit	64-Bit	64-Bit	64-Bit	64-Bit	64-Bit
PCB Height	1.18"	1.18"	1.18"	1.18"	1.18"	1.25"
Operating Temperature (°C)	TC=0°C to 85°C/ TC=-40°C to 85°C	TC=0°C to 85°C/ TC=-40°C to 85°C	TC=0°C to 85°C/ TC=-40°C to 85°C	TC=0°C to 85°C/ TC=-40°C to 85°C	TC=0°C to 85°C/ TC=-40°C ~ 85°C	TC=0°C to 85°C/ TC=-40°C ~ 85°C
Fully Lead-free Resistor	Yes	Yes	-	-	-	-

Server/Workstation Memory

RDIMM



Model Name	DDR5 RDIMM	DDR4 RDIMM
Speed	4800/5600/6400	2133/2400/2666/2933/3200
Density	16GB/32GB/64GB/128GB	4GB/8GB/16GB/32GB/64GB
Voltage	1.1v	1.2v
Pin Count	288-Pin	288-Pin
Width	80-Bit	72-Bit
PCB Height	1.23"	1.23"
Operating Temperature (°C)	TC=0°C to 85°C	TC=0°C to 85°C/ TC=-40°C to 85°C
Fully Lead-free Resistor	Yes	-

Server/Workstation Memory

ECC UDIMM



Model Name	DDR5 ECC CUDIMM	DDR5 ECC UDIMM	DDR4 ECC UDIMM	DDR3 ECC UDIMM	DDR2 ECC UDIMM
Speed	6400	4800/5600	2133/2400/2666/2933/3200	1066/1333/1600/1866	533/667/800
Density	16GB/32GB/48GB/64GB	16GB/32GB/48GB	4GB/8GB/16GB/32GB	2GB/4GB/8GB/16GB	1GB/2GB/4GB
Voltage	1.1v	1.1v	1.2v	1.5v/1.35v	1.8V
Pin Count	288-Pin	288-Pin	288-Pin	240-Pin	240-Pin
Width	72-Bit	72-Bit	72-Bit	72-Bit	72-Bit
PCB Height	1.23"	1.23"	1.23"	1.18"	1.18"
Operating Temperature (°C)	TC=0°C to 85°C	TC=0°C to 85°C/ TC=-40°C to 85°C	TC=0°C to 85°C/ TC=-40°C to 85°C	TC=0°C to 85°C/ TC=-40°C to 85°C	TC=0°C to 85°C
Fully Lead-free Resistor	Yes	Yes	-	-	-

Server/Workstation Memory

ECC SODIMM



Model Name	DDR5 ECC CSODIMM	DDR5 ECC SODIMM	DDR4 ECC SODIMM	DDR3 ECC SODIMM
Speed	6400	4800/5600	2133/2400/2666/2933/3200	1066/1333/1600/1866
Density	16GB/32GB/48GB/64GB	16GB/32GB/48GB	4GB/8GB/16GB/32GB	2GB/4GB/8GB/16GB
Voltage	1.1v	1.1v	1.2v	1.5v/1.35v
Pin Count	262-Pin	262-Pin	260-Pin	204-Pin
Width	72-Bit	72-Bit	72-Bit	72-Bit
PCB Height	1.18"	1.18"	1.18"	1.18"
Operating Temperature (°C)	TC=0°C to 85°C	TC=0°C to 85°C/ TC=-40°C to 85°C	TC=0°C to 85°C/ TC=-40°C to 85°C	TC=0°C to 85°C/ TC=-40°C to 85°C
Fully Lead-free Resistor	Yes	Yes	-	-

Very Low Profile Memory

DDR5/DDR4



Model Name	DDR5 VLP UDIMM	DDR5 VLP ECC UDIMM	DDR4 VLP RDIMM	DDR4 VLP UDIMM	DDR4 VLP ECC UDIMM	DDR4 VLP SODIMM
Speed	4800/5600	4800/5600	2133/2400/2666/2933/3200	2133/2400/2666/2933/3200	2133/2400/2666/2933/3200	2133/2400/2666/2933/3200
Density	16GB/32GB	16GB/32GB	4GB/8GB/16GB/32GB	4GB/8GB/16GB/32GB	4GB/8GB/16GB/32GB	4GB/8GB
Voltage	1.1V	1.1V	1.2v	1.2v	1.2v	1.2v
Pin Count	288-Pin	288-Pin	288-Pin	288-Pin	288-Pin	260-Pin
Width	64-Bit	72-Bit	72-Bit	64-Bit	72-Bit	64-Bit
PCB Height	0.738"	0.738"	0.738"	0.738"	0.738"	0.71"
Operating Temperature (°C)	TC=0°C to 85°C/ TC=-40°C to 85°C	TC=0°C to 85°C/ TC=-40°C to 85°C	TC=0°C to 85°C/ TC=-40°C to 85°C	TC=0°C to 85°C/ TC=-40°C to 85°C	TC=0°C to 85°C/ TC=-40°C to 85°C	TC=0°C to 85°C/ TC=-40°C to 85°C
Fully Lead-free Resistor	Yes	Yes	-	-	-	-

Rugged Memory

XR-DIMM



Model Name	DDR4 XR-DIMM
Speed	2133/2400
Density	8GB/16GB
Voltage	1.2v
Pin Count	300-Pin
Width	72-Bit
PCB Height	1.466"
Operating Temperature (°C)	TC=-40°C to 85°C

Product Features

- Highly durable 300-pin connector
- Employs durable mounting holes to enhance shock resistance
- Supports ECC error detection and correction
- On-DIMM thermal sensor

Value-added Technologies



Rugged Retention Strap



- 3-point fixation design
- Compatible with all motherboard designs
- Highly flame-retardant polysiloxane (Silicone) material
- Withstands temperatures up to 200°C
- Safe, user-friendly, and cost-effective solutions
- Supports various DIMM types: UDIMM, RDIMM, ECC UDIMM